

Cast Iron Gate Valves (OS&Y)

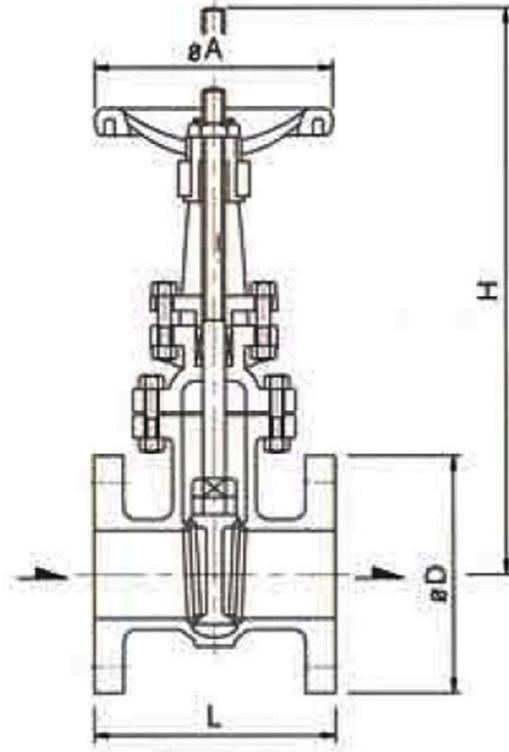

FEATURE

DN	40-300A	
PN	10K	
TEMP °C	≤120	
TEST MPa	ENCLOSURE (WATER)	1.6
	STRENGTH (WATER)	2.1
MEDIUM	WATER, STEAM	

DN	L	D	D ₁	b	Z-φd	H	W
40	180±1.5	140	105	20	4-φ19	248.5	φ190
50	180±1.5	155	120	20	4-φ19	261.5	φ190
65	190±1.5	175	140	22	4-φ19	286	φ190
80	200±1.5	185	150	22	8-φ19	325	φ210
100	230±1.5	210	175	24	8-φ19	381.6	φ240
125	250±1.5	250	210	24	8-φ23	417	φ260
150	270±1.5	280	240	26	8-φ23	455	φ270
200	290±1.5	330	290	26	12-φ23	558.5	φ300
250	330±1.5	400	335	30	12-φ25	674	φ350
300	350±3	445	400	32	16-φ25	780	φ390

MATERIALS

19	NUT	1	HMn58-2-2
18	SEMI-OPEN RING	4	STEEL Q235
17	WASHER	1	STEEL Q235
16	NUT	1	STEEL 25
15	NUT	2	STEEL 25
14	NUT	8	STEEL 25
13	BOLT	2	STEEL 35
12	BOLT	8	STEEL 35
11	GASKET	1	08+GRAPHITE
10	PACKING	1	GRAPHITE
9	DISC RING	2	BRASS
8	SEAT RING	2	BRASS
7	STEM NUT	1	BRASS
6	STEM	1	SS420
5	GLAND	1	DUCTILE IRON QT450-10
4	HANDWHEEL	1	CAST IRON
3	DISC	1	CAST IRON
2	BONNET	1	CAST IRON
1	BODY	1	CAST IRON

CÔNG TY CỔ PHẦN VẬT TƯ THIẾT BỊ PHÚ SONG LONG

Địa Chỉ: Số 4 - Đường Số 6 - KP. 6 - P.Hiệp Bình Phước - Q.Thủ Đức - TP.HCM

Điện thoại: 08.6680.1266 / 08.6660.5697 - Fax: 08.544.33.111

Hotline: 0972.46.25.36 - 0903.368.316 - 0936.36.00.93 *** Email: phusonglong@gmail.com

[Http://phusonglong.com](http://phusonglong.com) *** <http://phukiennanganhnuoc.com> *** <http://valvevietnam.com> *** [Http://matbich.com](http://matbich.com)