



Cast Iron Swing Check Valve



Specification

| | | |
|-------------------|---|---------------------------------|
| Applicable Fluid | Water, Fluid | |
| Working Pressure | less than 10 kgf/cm ² (Max. 1.0MPa) | |
| Applicable | below 80°C | |
| Connection Method | KS 10 K FF | |
| Hydraulic Test | Body | 21 kgf/cm ² (2.1MPa) |
| | Seat | 16 kgf/cm ² (1.6MPa) |

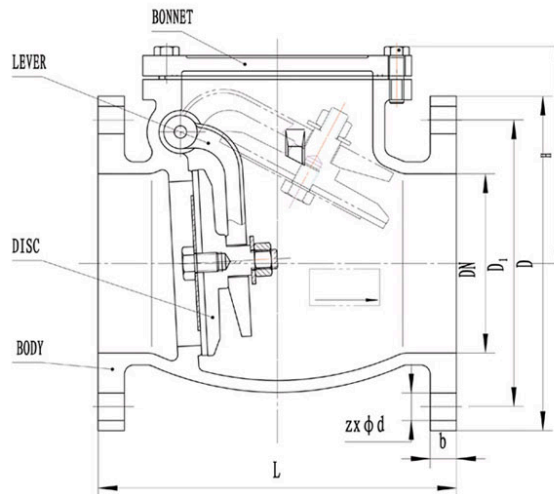

Materials

| | | |
|---|-----------|-----------|
| 1 | Body | Cast Iron |
| 2 | Seat | Brass |
| 3 | Disc | Cast Iron |
| 4 | Disc Ring | NBR |

Dimensions

| Name | mm | 40 | 50 | 65 | 80 | 100 | 125 | 150 | 200 | 250 | 300 |
|----------|------|--------|-------|--------|-------|-------|-------|-------|--------|--------|--------|
| Diameter | inch | 1 1/2" | 2" | 2 1/2" | 3" | 4" | 5" | 6" | 8" | 10" | 12" |
| L | mm | 190 | 190 | 190 | 215 | 245 | 285 | 295 | 390 | 500 | 540 |
| D | mm | 140 | 155 | 175 | 185 | 210 | 250 | 280 | 330 | 400 | 445 |
| D1 | mm | 105 | 120 | 140 | 150 | 175 | 210 | 240 | 290 | 355 | 400 |
| b | mm | 17 | 17 | 18 | 19 | 20 | 21 | 22 | 22 | 25 | 28 |
| Z-Fd | | 4-F19 | 4-F19 | 4-F19 | 8-F20 | 8-F19 | 8-F23 | 8-F23 | 12-F23 | 12-F25 | 16-F25 |
| H | mm | 101 | 102 | 113 | 118 | 134 | 156 | 182 | 206 | 269 | 333 |